



**TRIDENT®**

**HEXHALE®**



## **RTC5003**

**TRIDENT® HEXHALE® PAPER Complete  
System with Fast-Charging Extended  
Battery & Backpack**

**USER INSTRUCTIONS**

# RTC5100

## POWERED AIR PURIFYING RESPIRATOR HELMET WITH FACE SHIELD USER INSTRUCTIONS

*\*Designed to be used with PAPR system*



### SAFETY WARNINGS - READ BEFORE USING



#### WARNING

Read and Understand All Instructions Before Using.



TRIDENT® HEXHALE® powered air purifying face shield has a compact shape and a balanced centre of gravity. Used together with TRIDENT® HEXHALE® PAPR system, the overall filtration efficiency is as high as 99.997%. It is convenient, comfortable and easy to adjust, providing users with comprehensive protection for respiratory, eyes and face, head, and hearing (requires noise-cancelling earmuffs).

DO NOT USE WHERE THERE MAY BE A DEFICIENCY OF OXYGEN.

When using Class AUS and Class 1 filters – DO NOT USE IN HIGHLY TOXIC ATMOSPHERES, REFER TO AS/NZS 1715.

Provides P3 protection only with full facepiece respirator.

**Please do not raise the visor during usage, failure to follow this instruction to use this product may seriously affect the user's health.**



#### WARNING



- Use of this product for other operations, such as laser welding/cutting, can result in permanent eye damage and loss of vision.
- This product is not suitable for protection against x-rays, Gamma rays, high energy particulate radiation, lasers and masers.
- Please make sure the protection film is removed before use.
- Inspect the face shield before use to make sure it is fully assembled and functional, to ensure safety.
- Check before use to determine whether this product is suitable for your application.
- Replace the protective visor immediately if pitted, scratched or broken, otherwise it will reduce vision clarity, or reduce impact protection.
- Before using the face shield, ensure that you have read and understood the instructions. The Warranty Terms do not cover problems such as those caused by: unauthorised modifications; using unauthorised spare parts; abuse; failure to follow the instructions; improper maintenance; repairing.
- It will not provide protection against IR.
- There are only original spare parts (See page 8) to be installed. For information about suitable spare parts please contact the dealer or manufacturer.
- The duration of use depends on various factors such as use, cleaning storage and maintenance. Frequent inspections and replacement if it is damaged are recommended.
- Materials which may come into contact with the wearer's skin could cause allergic reactions to susceptible individuals.

- Eye-protectors against high speed particles worn over standard ophthalmic spectacles may transmit impacts, thus creating a hazard to the wearer.
- If protection against high speed particles at extreme temperatures is required then the selected eye-protector should be marked with the letter T immediately after the impact letter, i.e. FT, BT or AT. If the impact letter is not followed by the letter T then the eye protector shall only be used against high speed particles at room temperature.
- If the symbol F, B and A are not common to both the ocular and the frame, then it is the lower level which shall be assigned to the complete eye-protector.
- The optical class 3 oculars are not intended for long term use.
- For a face shield to comply with field of use symbol 8, it should be fitted with a filter of scale number 2-1,2 or 3-1,2 and have a minimum thickness of 1.4mm.
- For an eye-protector to comply with field of use symbol 9, both the frame and ocular shall be marked with this symbol together with one of the symbol F, B and A.
- The user shall contact the health and safety representative to ensure they are given the proper protection by the personal eyewear during working conditions.
- Substitute parts, films not included in instruction manual, or spraying or other modifications to face shield will seriously damage the product's protective function and void the warranty or cause the product's use effect to be inconsistent with protection level and certification.
- Failure to strictly follow all instructions for use and/or to wear product incorrectly throughout exposure can damage wearer's health, resulting in serious or fatal illness, injury, or permanent disability.
- Dispose of waste product parts in accordance with local regulations.

**Before / after using RTC5100 face shield, Check the following items:**

- If the protective visor is soiled, change the visor.
- Make sure there is sufficient ambient light.
- Replace worn or damaged parts immediately.
- Do not use parts other than those produced by TRIDENT®.
- Headgear must be adjusted to fit properly before use.
- Make sure the face seal is securely and properly attached.
- Make sure the breathing tube is securely assembled.
- The face shield should be stored in dry, cool area when not using it for long time.

	<b>WARNING</b> Severe personal injury could occur if the user fails to follow the above mentioned warnings, and/or fails to follow the operating instructions.	
-------------------------------------------------------------------------------------	-------------------------------------------------------------------------------------------------------------------------------------------------------------------	-------------------------------------------------------------------------------------

**COMMON PROBLEMS AND REMEDIES**

- **Poor vision**
  1. Protective visor is soiled (change visor).
  2. Where there is insufficient ambient light.
  3. Check if removing the film on the visor.

	<b>WARNING</b> The user must stop using the face shield immediately if the above mentioned problems cannot be corrected. Contact the distributor.	
-------------------------------------------------------------------------------------	------------------------------------------------------------------------------------------------------------------------------------------------------	-------------------------------------------------------------------------------------

## INSTRUCTIONS FOR USE

**WARNING!** Before using the face shield, ensure that you have read and understood the safety instructions.

### • ADJUST HEADGEAR

**Step 1:** Put the face shield on and adjust the face seal, make sure the face seal is fully sealed around the face (See fig.1b).

**Step 2:** Adjust the back headgear knob until the face shield is fixed on the head properly (See fig.1c).

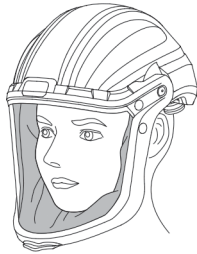

fig.1a

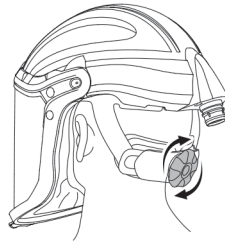

fig.1b

### • FACE SHIELD HEIGHT ADJUSTMENT

If you feel uncomfortable or unbalanced when wearing face shield, adjust the front and rear attachment positions of the suspension headband to an appropriate position (See fig.2). The suspension headband can be adjusted at four locations: two in the rear and two in the front.

Each location can be adjusted independently for a custom fit.

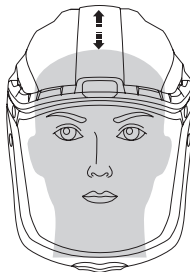

fig.2

Remove the headgear assembly (See fig.3a).

To change the position of the front headband, pull the attachment buckle out of the slot and rotate the buckle 90° clockwise to detach it from the peg. Re-position the peg to another slot on the "ladder" of the buckle, then follow the reverse steps to reinstall the buckle into place (See fig.3b).

To change the position of the rear headband, pull the height adjustment slot off the peg and re-position it to another slot on the "ladder" (See fig.3b).

Put the face shield on to check if it fits comfortably. Repeat the aforementioned steps if necessary.

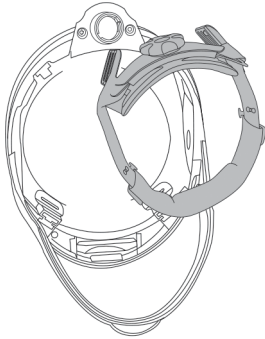

fig.3a

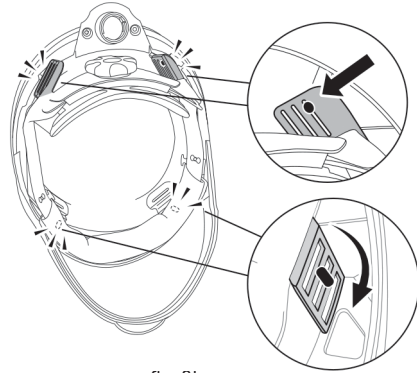

fig.3b

- **AIR FLOW DIRECTION ADJUSTMENT**

Toggle forehead air flow direction adjustment plate to adjust direction of the airflow in face shield to ensure comfortable wearing (2 gears adjustable) (See fig.4).

- **CONNECT HOSE TO HELMET**

Pull the head of hose to connect it to protruding connector of RTC5100 helmet, and then release the head of hose to complete the fixing (See fig.5).

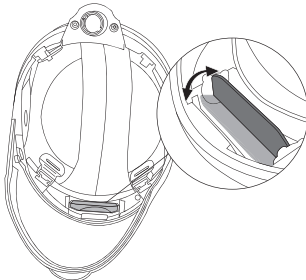

fig.4

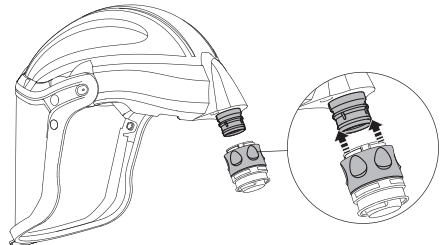

fig.5

## MAINTENANCE

### • REPLACING PROTECTIVE VISOR

**To remove visor:** Pull up the latches and remove buckles from both sides (See fig.6a / 6b), keep the parts appropriately. Push the central of visor top edge from internal side, until you hear a "click" to get out the visor (See fig.7a / 7b).

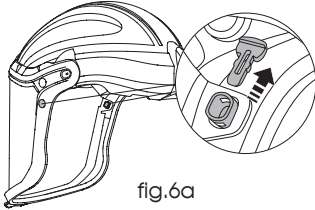

fig.6a

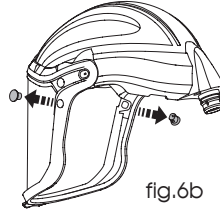

fig.6b

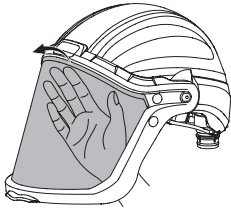

fig.7a

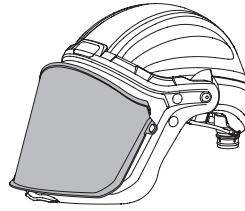

fig.7b

**To install visor:** Put the one side of the visor into the slot (See fig.8a) and then put the other side of the visor into the slot (See fig.8b / 8c). Press the center of the top edge of the visor inward from the outer side until you hear a "click" sound to fix the visor (See fig.8d). Place the buckles in the position shown and slide down the latches firmly until you hear a "click" sound (See fig.8e).

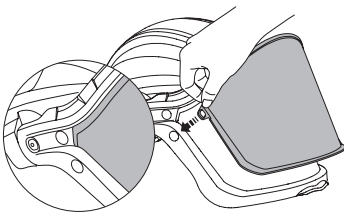

fig.8a

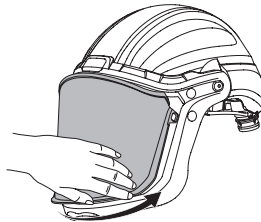

fig.8b

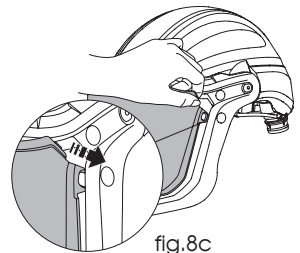

fig.8c

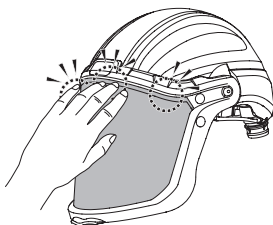

fig.8d

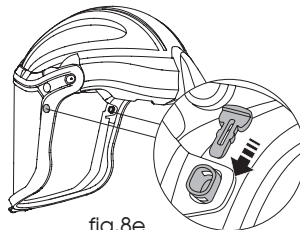
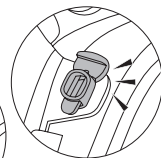

fig.8e



• **REPLACING FACE SEAL**

Fix the edge groove of the face seal to the edge of the outside frame of the face shield (See fig.9a), and press to the arrow direction to complete the installation (See fig.9b), and hang the inner and outer elastic bands on both sides to the "T" hook to fix (See fig.9c).

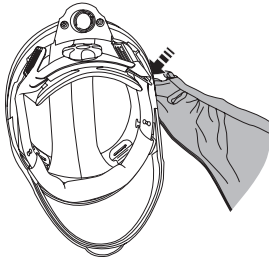

fig.9a

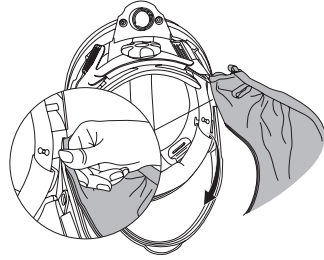

fig.9b

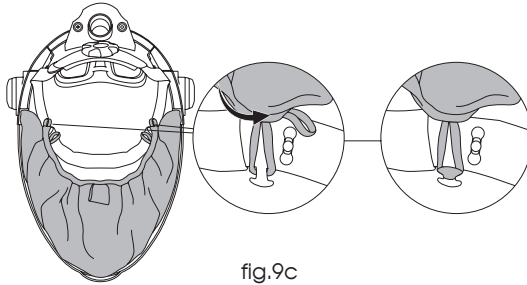

fig.9c

• **FOREHEAD SEAL AND BACK PAD REPLACEMENT**

Remove headgear from face shield (See fig.10a / 10b).  
Replace forehead seal and back pad with new one, and then put complete headgear back into face shield (See fig.10c).

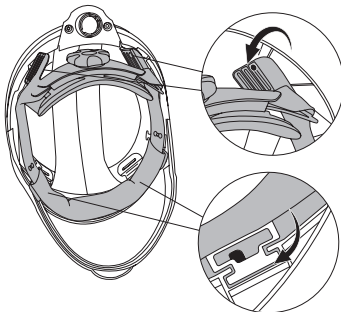

fig.10a

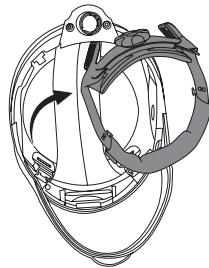

fig.10b

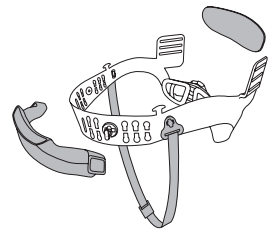

fig.10c

Remove soft band from headgear and replace with a new webbing (See fig.11). Rotate buckles on both sides of headgear, remove old chin strap, and after installing new chin strap, rotate buckles to complete the fixing (See fig.12).

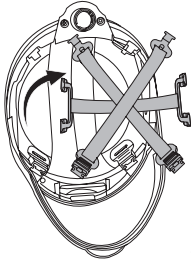

fig.11

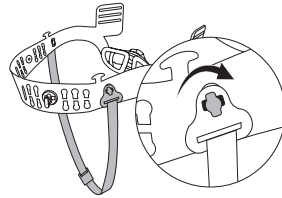

fig.12

• **REPLACING VISOR FRAME ASSEMBLY**

Push out the bottom from inside of the visor (See fig.13a), disassemble two buttons from both sides (See fig 13b, remove the visor frame assembly and replace the new one (See fig 13c).

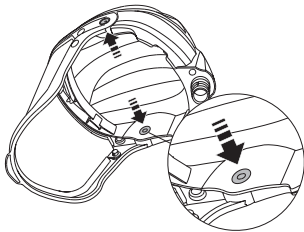

fig.13a

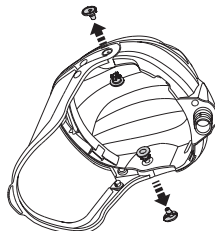

fig.13b

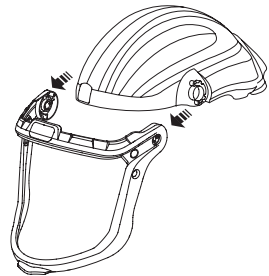

fig.13c

• **CLEANING AND DISINFECTION**

Clean the face shield by wiping with a soft cloth. Clean the visor surfaces regularly. Do not use strong cleaning solutions. Clean it with methylated spirit and clean cloth and wipe dry with a lint-free cloth.

**TECHNICAL SPECIFICATIONS**

Face Shield Model No.:	RTC5100
Viewing Area:	426cm <sup>2</sup> (66sq. in)
Operating Temp.:	-10°C ~ 50°C (14°F ~ 122°F)
Storing Temp.:	-30°C ~ 50°C (-22°F ~ 122°F)
Application Industry:	Painting / Metal Processing / Other applications with hot particles

## CERTIFICATION AND COMPLIANCE

Certification:



AS/NZS 1716:2012  
LIC. SMK41528

When used in conjunction with a TRIDENT® HEXHALE® complete blower system RTC5200 and the selected certified filter, AS/NZS 1716:2012 is achieved.

Compliance:

AS/NZS 1337.1:2010  
AS/NZS 1801:1997+Amdt 1-1999

## PARTS LIST & ASSEMBLY

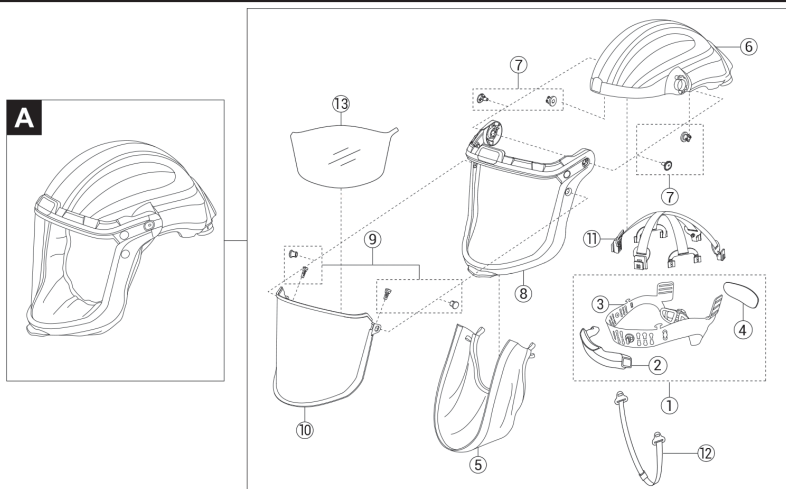

ITEM	PART NO.	DESCRIPTION
A-1	RTC5101	Headgear
A-2	RTC5102	Forehead Seal
A-3	RTC5103	Head Suspension
A-4	RTC5104	Comfort Back Pad
A-5	RTC5105	Standard Face Seal
A-6	RTC5106	Headtop
A-7	RTC5107	Headtop Buttons
A-8	RTC5108	Visor Frame Assembly
A-9	RTC5109	Visor Frame Buttons
A-10	RTC5110	Protective Visor
A-11	RTC5111	Ribbon
A-12	RTC5112	Chin Strap
A-13	RTC5113	Disposable protective film for the visor

# RTC5200

## POWERED AIR PURIFYING RESPIRATOR COMPLETE BLOWER SYSTEM USER INSTRUCTIONS



### SAFETY WARNINGS - READ BEFORE USING



#### 1. WARNING



1. This product is part of a system that helps reduce exposures to certain airborne contaminants, including dust, pollutants, fine particles, vapours or gases as well as other contaminants. Before use, the wearer must read and understand these User Instructions. Misuse may result in injury, sickness or death.
2. The TRIDENT® HEXHALE® battery, chargers, and the TRIDENT® HEXHALE® PAPR assembly are not intrinsically safe. Do not use it in flammable or explosive atmospheres. Doing so may result in serious injury or death.
3. DO NOT USE WHERE THERE MAY BE A DEFICIENCY OF OXYGEN.
4. When using a Class AUS and Class 1 filters – DO NOT USE IN HIGHLY TOXIC ATMOSPHERES, REFER TO AS/NZS 1715.
5. Provides P3 protection only with full facepiece respirator.
6. Always correctly use and maintain the Lithium-ion battery pack. Failure to do so may cause fire or explosion or could adversely affect respirator performance and result in injury, sickness, or death.
  - a. Do not charge batteries with unapproved chargers, in enclosed cabinets without ventilation, in hazardous locations, or near sources of high heat.
  - b. Do not immerse the product in any liquid.
  - c. Do not use, charge, or store battery out of the recommended temperature range.
  - d. Charge in an area free of combustible material and readily monitored.
7. Failure to follow these User Instructions may reduce respirator performance, overexpose you to contaminants, and may result in injury, sickness, or death.
  - a. Do not use with parts or accessories other than those manufactured by TRIDENT® as described in these User Instructions.
  - b. The TRIDENT® HEXHALE® Powered Air Purifying Respirator is one component of an approved respiratory protection system. Always read and follow all User Instructions supplied with your TRIDENT® HEXHALE® headtop and other system components in order to ensure correct system operation.
  - c. Do not turn off the blower, remove the headtop, or reach your hand into the headtop while inside the contaminated area. This could allow contaminants to enter the respirator and may result in sickness or death.

8. Always correctly use and maintain the filter assembly. Failure to do so may reduce respirator performance, overexpose you to contaminants, and may result in sickness or death.
  - a. Inspect the filter before each installation.
  - b. Always properly install the filter into the blower unit.
  - c. Never attempt to clean filter by knocking or blowing out accumulated material. Doing so will damage the filter media.
  - d. Use of the spark screen is mandatory for welding and all situations where the TRIDENT® HEXHALE® Powered Air Purifying Respirator may be exposed to sparks, molten metal or other hot particulates. Failure to use the spark screen when needed may allow the filter to catch fire or be damaged and allow contaminants to enter the respirator and may result in injury, sickness or death.
  - e. Store the filter as described in these User Instructions under the recommended storage temperature conditions and adhere to filter expiration dates.
  - f. The filter loading indicator is for particulate loading levels only.
  
9. To reduce exposure to hazardous voltage:
  - a. Do not attempt to service the chargers. There are no user-serviceable parts inside.
  - b. Do not substitute, modify or add parts to the chargers.
  - c. Inspect the chargers and power cords before use.  
Replace if any parts are damaged.
  - d. Do not use the chargers outdoors or in wet environments.

## 2. SYSTEM DESCRIPTION

The TRIDENT® HEXHALE® Powered Air Purifying Respirator (PAPR) is designed to provide respiratory protection against particulates, vapours or gases. The TRIDENT® HEXHALE® is not an intrinsically safe system.

The TRIDENT® HEXHALE® PAPR includes a blower unit, filtration unit, breathing tube assembly and a battery. The RTC5200 blower unit is equipped with a digital display screen that shows current particle filter loading. The built-in optical sensor design ensures that the device cannot be used without a filter box.

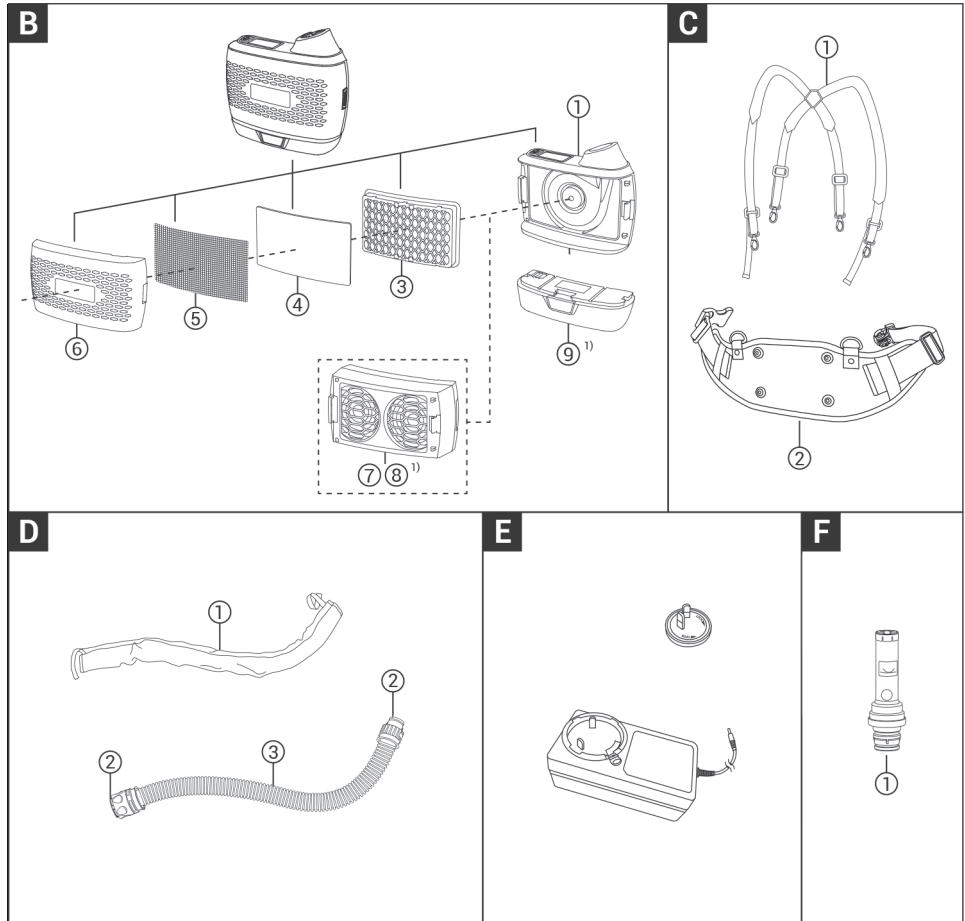

ITEM	PART NO.	DESCRIPTION	PERIOD OF OBSOLESCENCE
<b>B. BLOWER UNIT</b>			
B-1	RTC5201	TRIDENT® Blower Body	5 years (manufacture date on product label)
B-2	RTC5202	TRIDENT® Fast-charging Standard Battery	5 years (manufacture date on product label)
B-3	RTC5203	TRIDENT® Particle Filter (P3 filter)	5 years (manufacture date on product label)
B-4	RTC5204	TRIDENT® Pre-filter	5 years (manufacture date on product label)
B-5	RTC5205	TRIDENT® Spark screen	5 years (manufacture date on product label)
B-6	RTC5206	TRIDENT® Filter Cover	5 years (manufacture date on product label)
B-7 <sup>1)</sup>	RTC5207	TRIDENT® Gas filter (A1B1E1K1)	5 years (manufacture date on product label)
B-8 <sup>1)</sup>	RTC5208	TRIDENT® Gas filter (A1)	5 years (manufacture date on product label)
B-9 <sup>1)</sup>	RTC5209	TRIDENT® Fast-charging Extended Battery	5 years (manufacture date on product label)
<b>C. WEARS</b>			
C-1	RTC5301	TRIDENT® Shoulder Strap	5 years (manufacture date on product label)
C-2	RTC5302	TRIDENT® Belt Cushion (Including Screws and Washers)	5 years (manufacture date on product label)
<b>D. HOSE</b>			
D-1	RTC5401	TRIDENT® Hose Cover	5 years (manufacture date on product label)
D-2	RTC5402	TRIDENT® O-Ring	5 years (manufacture date on product label)
D-3	RTC5403	TRIDENT® Quick-Connection Hose (Including O-Ring)	5 years (manufacture date on product label)
<b>E. BATTERY CHARGER</b>			
E-1	RTC5404	TRIDENT® Fast-Charging Battery Charger Set	5 years (manufacture date on product label)
<b>F. AIRFLOW INDICATOR</b>			
F-1	RTC5405	TRIDENT® Airflow Indicator II	5 years (manufacture date on product label)



<sup>1)</sup> It is not included in the product, and needs to be purchased separately.

### 3. LIMITATIONS OF USE

- This PAPR product is not suitable for the applications which request intrinsic safety (IS).
- Oxygen deficient atmospheres.
- Contaminants generated in workplace and concentrations that are unknown or immediately dangerous to life or health (IDLH).
- Oxygen concentration of the air in the workplace is 17% or lower.
- Do not use the product until it is fully assembled, as incomplete assembly may pose a danger to human life.
- Do not use in enclosed places or in locations with the risk of fire or explosion.
- Do not use the product with its power turned off, as it may lead to an increase in carbon dioxide concentration and a decrease in oxygen levels inside the headtop. In the power-off state little or no respiratory protection is to be expected.
- Do not use the product if it does not supply enough air (minimum 170-lpm).
- Do not use in workplaces with strong winds, as the negative pressure generated inside the headtop may allow outside air to enter, posing potential risks.

### 4. MARKINGS

#### MARKINGS ON THE EQUIPMENT

AS/NZS 1716:2012 Respiratory protective device	
TH3 P R SL: Classification of complete device	
TH3: Assigned protection factor 40, normal protection factor 500, higher strength requirement for breathing house couplings	
P: Particulates    R: Replace    SL: Test against sodium chloride and paraffin oil	
 	Read the instructions before use
	Recycle

#### MARKINGS ON THE FILTER

MARKING	PART NO.	COLOUR CODE	PROTECTION AGAINST
P (R SL)	RTC5203	White	Particulates (R=Replaceable, SL=Test Against Sodium Chloride and Paraffin Oil)
A1B1E1K1	RTC5207	Brown / Grey / Yellow / Green	Organic gasses / Inorganic gasses / Sulfur dioxide, Acidic gasses / Ammonia and organic ammonia derivatives
A1	RTC5208	Brown	Organic gas and vapour, boiling point > 65°C

#### CERTIFICATION

When used in conjunction with a TRIDENT® HEXHALE® Helmet with Face Shield and the selected filter from the above table compliance to AS/NZS 1716:2012 is achieved.



AS/NZS 1716:2012  
Lic. SMK41528

## 5. COMPONENT DESCRIPTION & ASSEMBLY

### 5.1 BLOWER

#### 1. OPERATION PANEL

- The digital screen provides information on battery life, airflow level, and filter loading. If any issues arise, the user should promptly leave the contaminated area, inspect the device, and resolve the problems before returning to work.

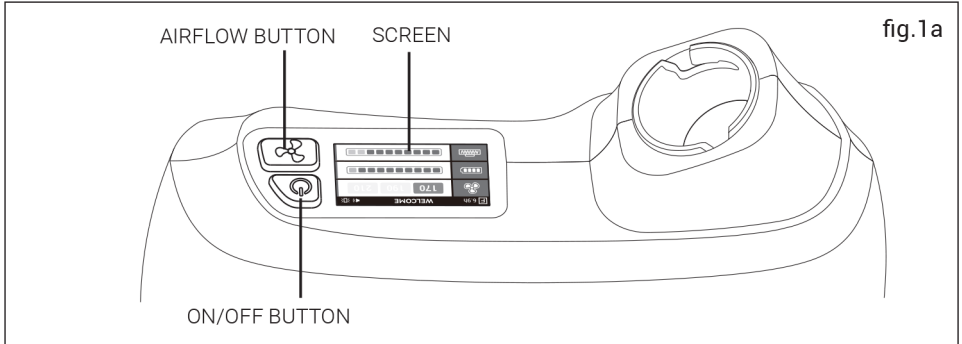

fig.1a

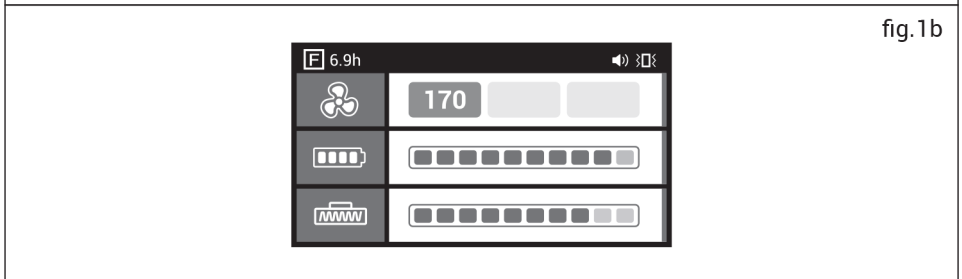
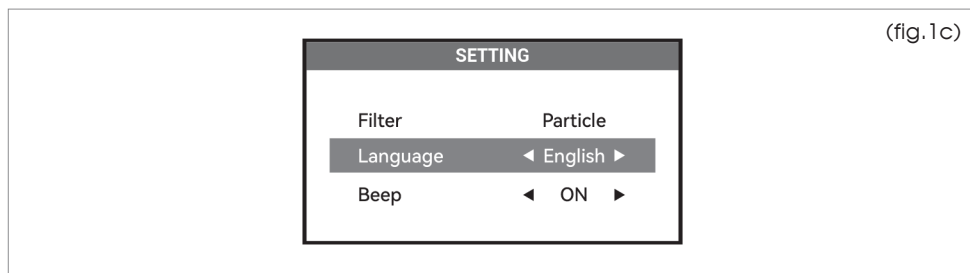

fig.1b

	Upper Left Corner	Total used time of the filter (Note: 'total used time' here refers to the used time of the filter which is closest to the blower)
	Airflow Control	3-level adjustable airflow (170/190/210+lpn)
	Battery Status	Display the remaining battery
	Filter Loading Indicator	Display the filter loading

## 2. SETTINGS (fig.1c)



### GENERAL SETTINGS

Open the setting page	Short-press the on/off + airflow switch button
Select a setting item	Short-press the on/off button
Change settings for selected item	Short-press the airflow switch button
Save settings	Long-press the airflow switch button
Switch the display orientation	Long-press the on/off + airflow switch button

### SETTING ITEMS

Filter	Select the filter that is currently in use. Can be set to 'P3 Filter' or 'Compound Filter (P3 Filter + Gas Filter)
Language	Select the displayed language on the screen (English)
Total used time	Display the total used time of the blower
Version info	Current software version info
Pairing codes	Current software pairing code
Buzzer	Buzzer alarm can be enabled or disabled under normal conditions
Vibration	Vibration can be enabled or disabled under abnormal conditions

## 5.2 BATTERY

- Battery is a fast-charging extended battery, the duration of this battery may vary when using different filter components. It is recommended to choose this fast-charging extended battery to match the gas filter.

### 1. REMOVAL AND INSTALLATION OF THE BATTERY

- To remove the battery: Press the button and pull the battery pack out following the direction in fig. 2a/2b/2c. Detach it from the body.
- To install the battery: Attach the battery to the blower body, pushing until it clicks (see fig. 3a/3b).

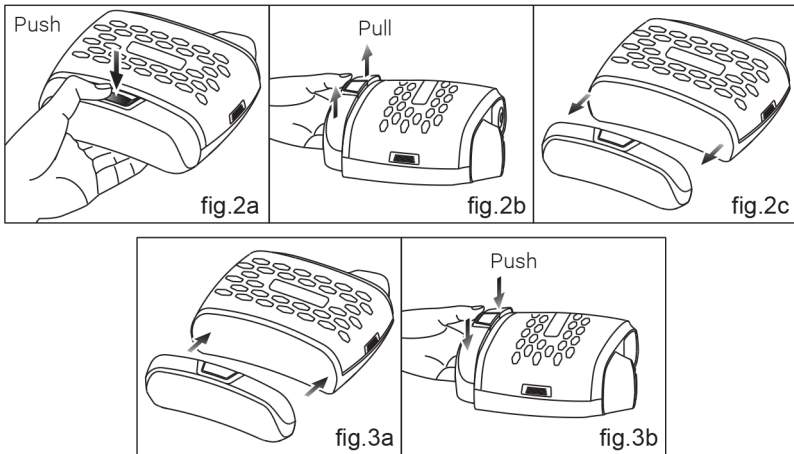

### 2. CHARGE THE BATTERY

- Remove the battery pack from the blower assembly. Connect the charger cord to the battery terminal (Fig.4a).
- Red LED: In Charging, Green LED: Battery Full and Flashing Red LED: Not Charging.
- When the charger indicator turns from red to green (Fig. 4b), do not stop charging immediately; continue charging for an additional 0.5h.
- Close the port plug when charging is finished.

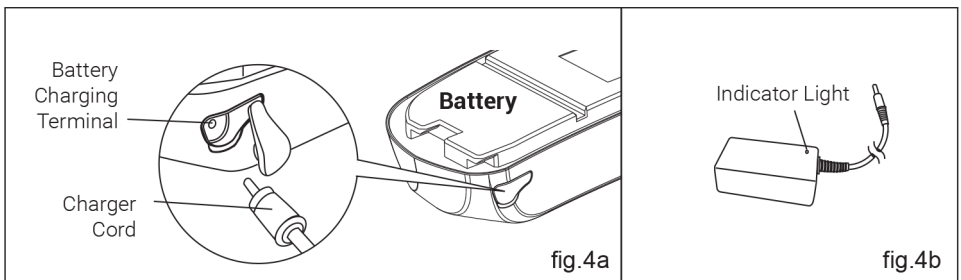

### 3. INSTALLING THE ADAPTOR

- Align the adapter with the bayonet fitting, press down, and turn toward the “open” direction until it is fixed into place. (See Fig.5b)

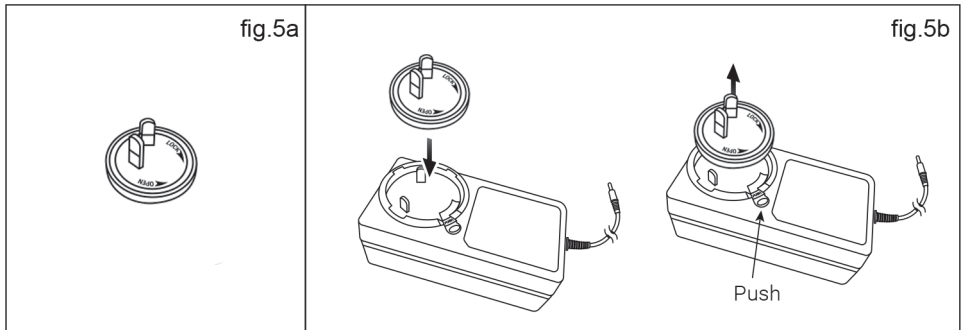

### 5.3 SPARK SCREEN, PREFILTER, PARTICLE FILTER AND COVER

#### 1. INSTALL THE FILTER (SPARK SCREEN, PRE-FILTER, PARTICLE FILTER, GAS FILTER)

- Power must be turned off when replacing the filters. Install the spark screen, pre-filter, particle filter and gas filter in filter cover. (Fig.6a).
- Before installation, ensure the filter is undamaged and dry with no tears or other damage. Attach the filter cover to the blower unit by engaging tabs on the filter cover into the slot on the blower unit and snapping the other side into the opposite slot. Push the filter cover down until the latch clicks into the blower unit. Inspect both sides of the filter cover to verify that it is properly installed. To replace the filter, press the latch to open the filter cover (Fig. 6b).

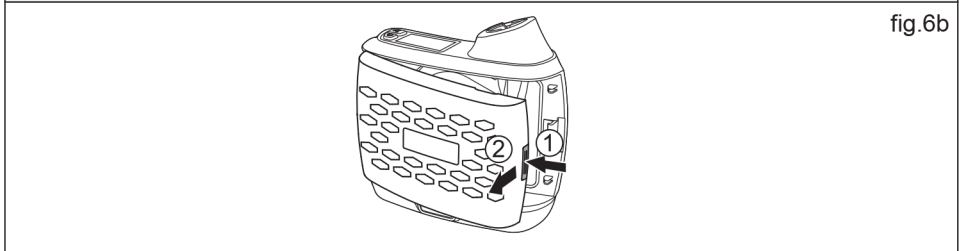
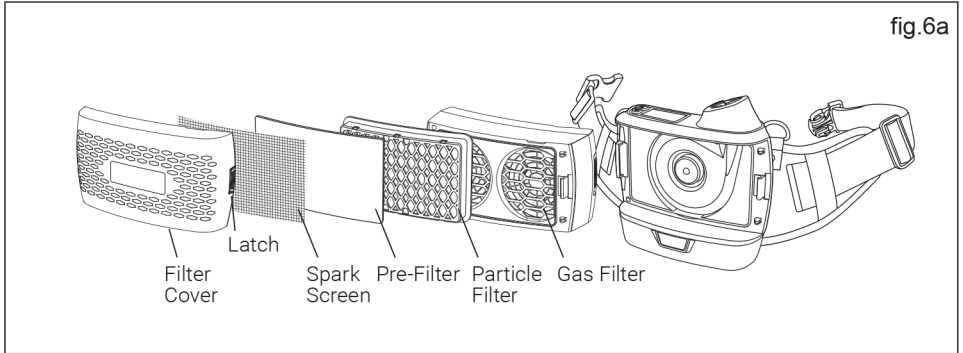

## 5.4 BREATHING TUBE

### 1. ASSEMBLING

- Insert the two prongs on the breathing tube into the blower unit and headtop receptacle (Fig.7), twist 1/4 turn to the anti - "OPEN" direction to lock into place (Fig.8a).

### 2. DISASSEMBLING

- Twist 1/4 to the "OPEN" direction and then take the prongs out from the end (Fig.8b).

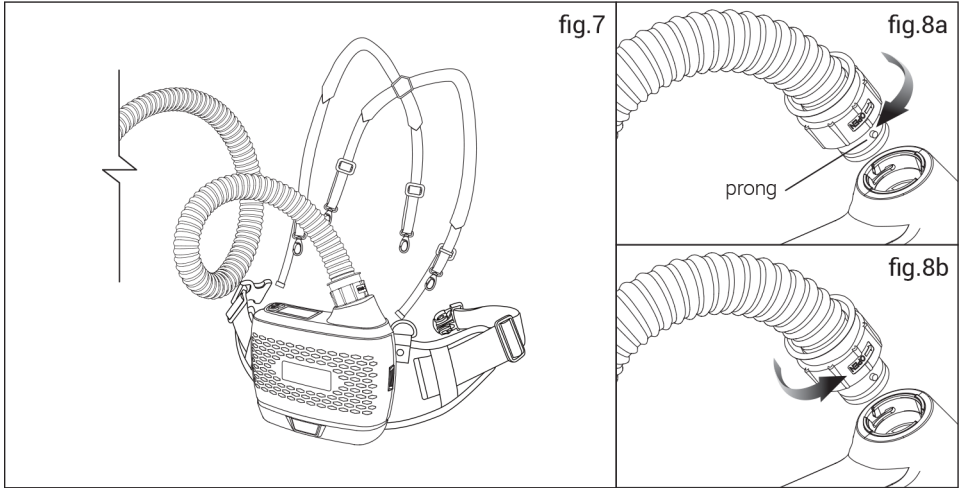

## 5.5 SHOULDER STRAP & BELT CUSHION (BACKPACK)

- Connect the hooks to the belt (Fig.9).

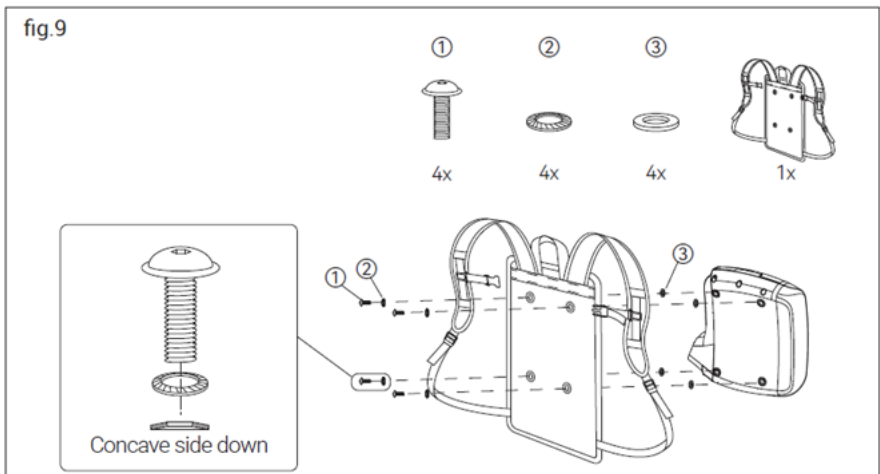

## 6. OPERATING INSTRUCTIONS

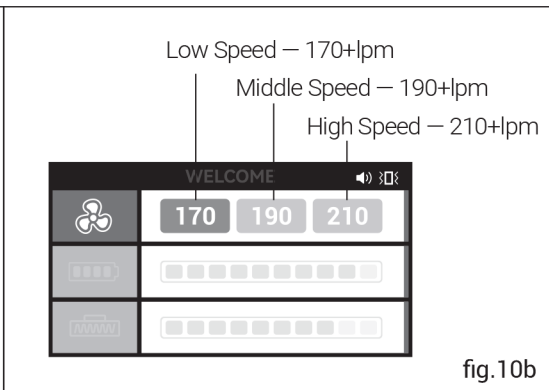
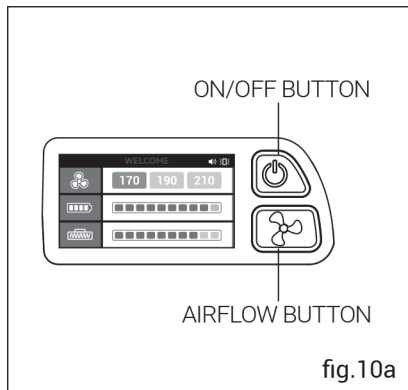

### 1. Power On

Long-press for 3 seconds.



### 2. Power Off

Long-press until beeping sounds finish.

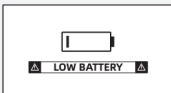

### Select Airflow

Press the button to switch between 170+lpm, 190+lpm and 210+lpm.

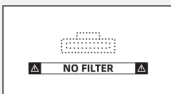
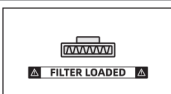
ALARM	DISPLAY	SOUND	VIBRATION
Low Battery	 <p>Continuous Flash</p>	Beeping sound repeats every 35 seconds, sounding twice in succession, with each tone lasting for 1 second.	Vibration repeats every 125 seconds, with each vibration lasting for 5 second.
Insufficient Airflow	 <p>Continuous Flash</p>	Beeping sound repeats every 1.5 seconds, with each tone lasting for 0.5 second.	Vibration repeats every 1.5 seconds, with each vibration lasting for 0.5 second.
Filter Missing / Misinstalled	 <p>Continuous Flash</p>	Beeping sound repeats every 1.5 seconds, with each tone lasting for 0.5 second.	Vibration repeats every 1.5 seconds, with each vibration lasting for 0.5 second.
Loaded Filter	 <p>Continuous Flash</p>	Beeping sound repeats every 1.5 seconds, with each tone lasting for 0.5 second.	Vibration repeats every 1.5 seconds, with each vibration lasting for 0.5 second.

## 7. INSPECTION

### 1. BLOWER ASSEMBLY

- Make sure the spark screen, pre-filter and particle filter are properly installed and securely latched.

### 2. BREATHING TUBE

- Ensure the breathing tube is undamaged and securely attached to both the blower unit and the headtop.

### 3. BATTERY

- Make sure the battery is fully charged before each use (battery needs to be charged before the first use). Ensure the battery is securely connected to the blower unit.

### 4. ALARM SOUND CHECK

- It is necessary to perform both the airflow rate test and the alarm sound check before use. After turning on the product, check the audible alarm function by blocking the \air outlet as shown in the diagram below (Fig.11). The warning signal on the panel should flash with a sound and blower vibration (approximately 15 to 30 seconds after the outlet is blocked). Ensure the filter is installed, and the battery is fully charged before conducting this test. The product is working correctly if the warning functions follow the process above.

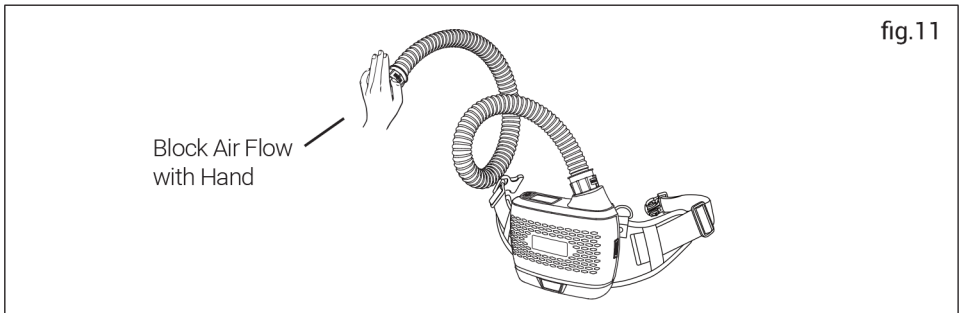

### 5. AIRFLOW RATE TEST

- Make sure all the components are fully assembled before testing.
- Connect the end of hose to the bottom of airflow indicator and then start the button. Keep the airflow indicator vertical (Fig.12). If the ball inside the pipe floating above the limited line in low-speed mode, it proves normal function. If the ball cannot float up to limited line, please refer to the TROUBLE-SHOOTING section on page 26.

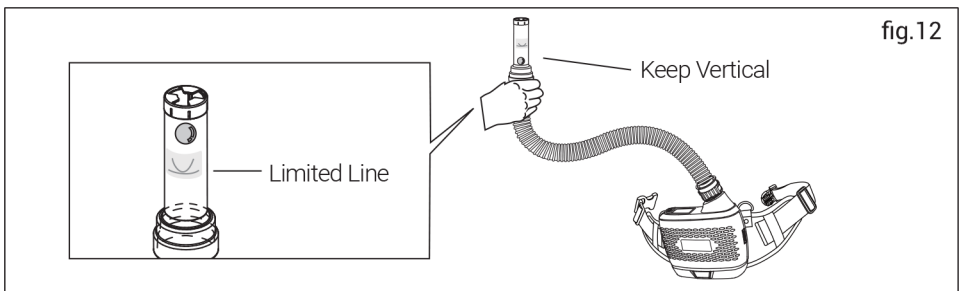

## 8. ENTER AND EXIT CONTAMINATED AREA

Prior to entering the contaminated area, complete the inspection procedures listed in these User Instructions and ensure the selected PAPR setup is appropriate protection for the given airborne contaminant and concentration.

1. Turn the blower on.
2. It is recommended to check both the airflow with the airflow indicator and low flow alarms.

**NOTE:** High environmental noise levels or use of hearing protection may interfere with the user's ability to hear audible alarms. User may need to check for the visual alarms more frequently in high noise environments.

3. Don the TRIDENT® HEXHALE® Powered Air Purifying Respirator and headtop. Enter the work area.
4. Leave the contaminated area immediately if any of the following conditions occur:
  - a. Any part of the system becomes damaged.
  - b. Airflow into the respirator decreases or stops.
  - c. The low airflow or low battery alarm triggers. In the event an audible or visual alarm triggers, the user should immediately leave the contaminated area.
  - d. Breathing becomes difficult.
  - e. You feel dizzy or your vision is impaired.
  - f. You taste or smell contaminants.
  - g. Your face, eyes, nose or mouth becomes irritated.
  - h. You suspect that the concentration of contaminants may have reached levels at which this respirator may no longer provide adequate protection.
5. Do not turn off the blower, remove the headtop, or reach your hand into the headtop in areas where the air is contaminated. This could allow contaminants to enter the respirator and may result in sickness or death.

## 9. CLEANING AND STORAGE

### 9.1 CLEANING

The respirator components must be cleaned, inspected and prepared for next use after each use. Use soft cloth dipped in mild soap water for wiping. Be careful with the water NOT to get inside the body

#### 1. BLOWER UNIT AND BATTERY

- Clean the outer surfaces of the PAPR and battery pack with a soft cloth dampened in a solution of water and mild, pH neutral detergent. Be careful that the water DOES NOT get inside the body. Do not use solvents or abrasive cleaners. Make sure the electrical contacts of the motor/blower and battery pack are dry before assembling.

#### 2. BREATHING TUBE

- Wiping the exterior is insufficient. Clean the hose surface and the connection part of the breathing tube with a soft cloth dipped in water and detergent solution. Ensure the breathing tube is completely dry before using or storing. They cannot be immersed in liquids for cleaning and must be replaced if wet.

#### 3. FILTER

- Open the filter cover and inspect all the filters and spark screen. The particle filter and pre-filter cannot be cleaned. The spark screen can be cleaned using a clean, soft cloth dipped in a solution of water and a mild pH neutral detergent. Completely dry the spark screen with a clean cloth. Replace the pre-filter and particle filter if excessively dirty, wet or damaged. Do not attempt to remove contamination using a compressed air line as this will automatically invalidate the warranty. If the spark screen cannot be cleaned or is damaged, replace with a new spark screen.

### 9.2 STORAGE

The TRIDENT® HEXHALE® PAPR system is not intrinsically safe. Keep away from flammable or explosive atmosphere. Store the product in a clean, dry and cool place.

#### 1. BLOWER

- Store the PAPR system at a temperature range between -10°C to 55°C (14°F to 131°F), in a clean environment without direct light.

#### 2. BATTERY

To help maximise battery service life:

- Disconnect the charger after a full charge has been received.
- Battery should be removed from the PAPR system if it is going to be stored for an extended period.
- Store the battery at -10°C to 55°C (14°F to 131°F), R.H. <85%, to get maximise battery service life.

## 10. TECHNICAL SPECIFICATIONS

Airflow Rate	Manufacturer's minimum design flow rate: 165+lpm (5.8+cfm)	
	Low speed: 170+lpm (6+cfm)	
	Medium speed: 190+lpm (6.7+cfm)	
	High speed: 210+lpm (7.4+cfm)	
Fast-charging Extended Battery	Battery type: rechargeable Li-ion battery	
	Battery run time: 19h (170+lpm); 17h (190+lpm); 15h (210+lpm)	
	Battery charge time: 2.5 hour (Extended Battery)	
	Battery life: ≥ 550 charges	
Filter	Filter efficiency: 99.997%	
	Alarms: Visible, audible and vibrate	
	Limited storage life	<p>Unopened filter: 5 years after manufacture. For details, refer to the date of manufacture information on the filter label.</p> <p>Installed filter: should be well-kept under instruction given condition. For an installed filter which has not been used, it is suggested to store no more than one year.</p>
Temperature	Operating temperature: -5°C to 55°C (23°F to 131°F)	
	Storage temperature: -10°C to 55°C (14°F to 131°F)	
	Charging temperature: 0°C to 40°C (32°F to 104°F)	
Relative Humidity (R.H.)	Operating R.H.: < 90%	
	Storage R.H.: < 85%	
	Charging R.H.: 20%–85%	
Weight	1050g (Blower unit + fast-charging standard battery)	
Respirator Approval	EN12941:1998+A1:2003+A2:2008 TH3 P R SL AS/NZS1716: 2012 - RTC5000, Particle filter with class P3 inside UKCA, UKNI, EAC	

## 11. TROUBLE-SHOOTING GUIDE

PROBLEMS	CAUSES	TROUBLE-SHOOTING
No airflow from the blower	Blower not ON	Long press on the ON button.
	Battery no power	Charge the battery.
	Battery not installed properly	Check and reassemble the battery.
	Tube blocked/air leakage	Check and clear the obstruction.
Airflow test failed	Hose may get blocked/air leakage	Check the tube status.
	Dirty filter	Replace the filter.
Insufficient battery life	Battery fault	Replace the battery.
	Inadequate charging	Fully charge battery.
	Filter is clogged	Replace the filter.
	Damaged charger	Replace the charger.
Increased noise level		Replace the filter and pre-filter as required.
Warning indicator ON, blower vibrates and alarm sound bleeping	Tube gets blocked/air leakage	Check if tube/anywhere gets blocked before use.
	Filter assembled without removing the package	Check if the package is removed.
You smell or taste contaminants	Damaged filter	Check the filter status and replace the filter if needed.
	Hose with leakage problem	Examine the tube assembly.
	Absence of essential filter component	Identify the missing filter and install the appropriate one.

## WARRANTY

TRIDENT's only obligation shall be repair, replace or refund the purchase price of such parts or products material and fabrication defects free of charge within the warranty period.

This warranty does not cover any issues caused by improper handling, abuse, or applications other than recommended in the user instruction.

If you come across any problem during warranty period, contact your distributor, send the defective parts together with the completed defect problem if necessary.

-----

Thank you for choosing a TRIDENT® HEXHALE® product.

For future reference, please complete the owner's record below :

**Serial Number:**

**Batch Number:**

**Purchase Date:**

**TRIDENT® HEXHALE® PAPR**  
**MAKE A WARRANTY CLAIM**  
  
Scan the code or go to  
[industree.com.au/papr-warranty](http://industree.com.au/papr-warranty)



AN INDUSTREE GROUP BRAND

Industree Group Pty Ltd  
3 Blade Close, Berkeley Vale, NSW 2261, Australia  
INDUSTREE.COM.AU

Certification body details:



SAI Global Certification Services Pty. Ltd.  
Level 7 Suite 7.01 45 Clarence Street  
Sydney NSW 2000 Australia